

Gas ejectors

for two-stage liquid ring vacuum pumps

GOV 3211, GOV 3212 GPV 4011 . . . GPV 6312

Operating pressure: 4 to 80 mbar
Suction volume flow: 10 to 400 m³/h

CONSTRUCTION TYPE

Sterling SIHI gas ejectors are simple and sturdy vacuum gas ejectors with following particular characteristics:

- Adaptable to different operating conditions by adequate material selection
- Simple installation into the suction line of liquid ring vacuum pumps
- Low noise service which is free of maintenance and deficient in vibration

APPLICATION

Sterling SIHI gas ejectors extend the operating range of liquid ring vacuum pumps so that lower absolute pressures become possible (to 8 mbar).

Fields of application are e.g.:

Chemistry and pharmacy for distilling and degassing

Electric industry for impregnation and drying

Plastics industry for degassing etc.

The gases to be handled may be vapour saturated or aggressive. Sterling SIHI gas ejectors are used wherever the vacuum attainable by a liquid ring vacuum pump is not sufficient and where danger of running in cavitation is imminent for the liquid ring vacuum pump. Even if the suction side of the ejector is closed, the liquid ring vacuum pump is protected against cavitation.

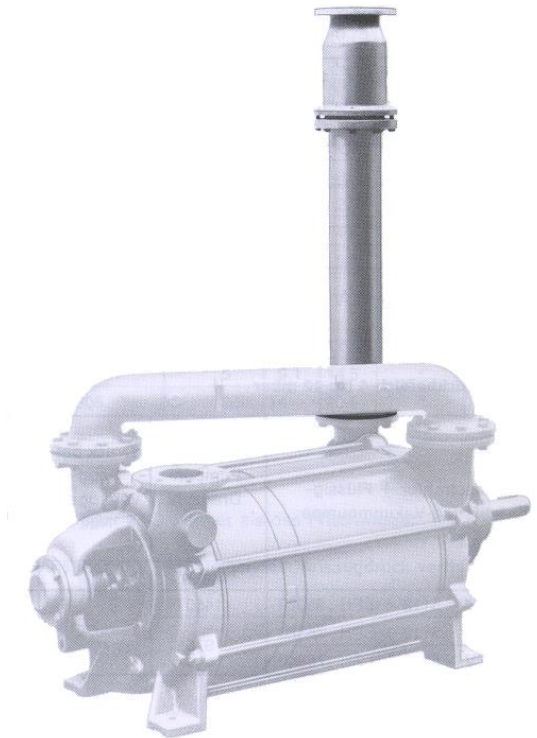

NOTE

The characteristics of the suction volume flow of the gas ejectors depend on essentially on the suction capacity of the liquid ring vacuum pump and therefore on the vapour pressure and temperature of the service liquid used. To meet with the different conditions, we offer 2 construction series.

Service liquid:	water up to 15°C	water up to 30°C
Suction pressure:	8 ... 40 mbar	20 ... 80 mbar
Series:	GOV 3211, 3212 GPV 4011 - 6012	GOV 3211, 3212 GPV 4311 - 6312

In case of particularly low suction the gas ejector GPV 5112 is available.

Service liquid:	water 15°C
Suction pressure:	4 ... 12 mbar

POLLUTION CONTROL: To reduce the exhaust blast the motive gas can be removed from the separator.

The standard combinations described in this catalogue list are optimal in view of suction volume flow, power absorption and service charges. Other combinations of gas ejectors and liquid ring vacuum pumps can be applied. Details on request.

Material design

Item	COMPONENTS	MATERIAL DESIGN	
		81	88
0951	Casing	0.6025	1.4408
0960	Venturi tube holder		0.6025
0969 *	Insert ring	-	1.4541
0970	Motive nozzle	hard rubber	1.4401
0975	Venturi tube		

In case of material design 88 the venturi tube holder is not in contact with the medium handled.

* only in case of material design 88

Sectional drawing

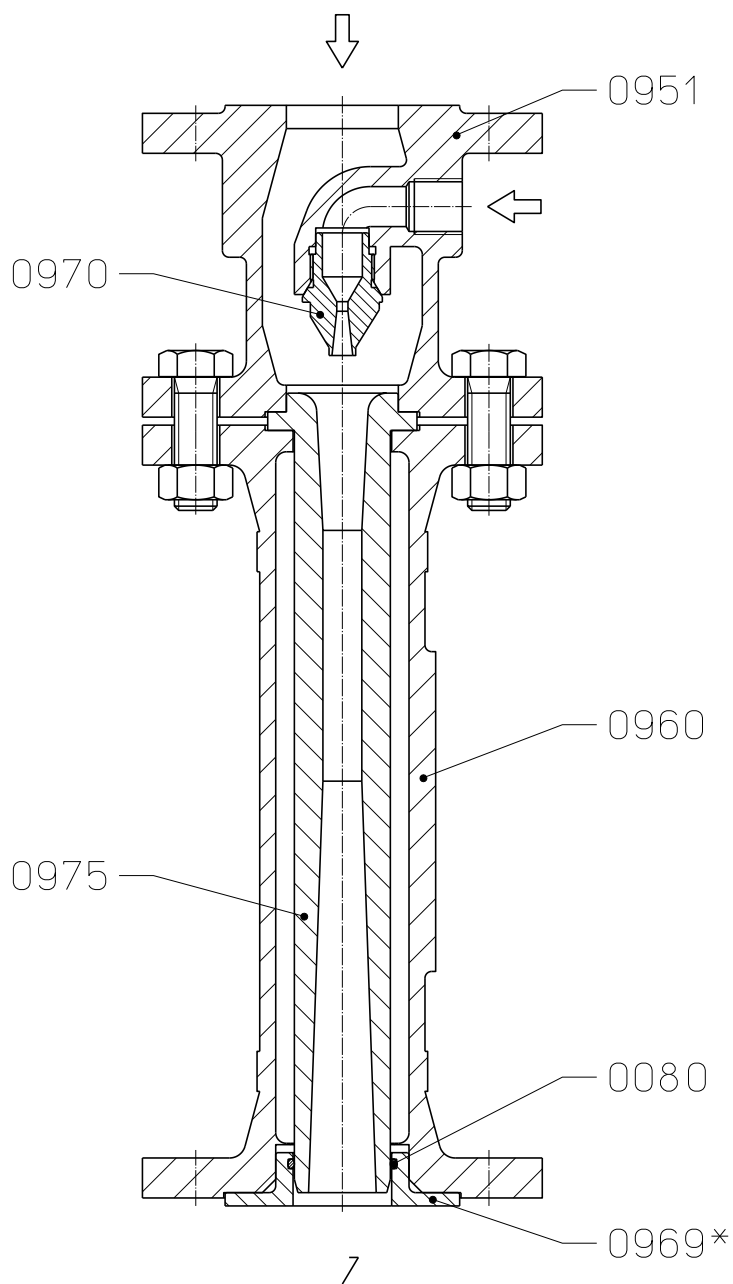

Technical Data

Suction pressure range 4 to 12 mbar

Service liquid temperature up to 15°C

gas ejector + liquid ring vacuum pump	pump speed rpm	rated power of the motor of the liquid ring vacuum pump kW	pressure at a suction volume flow = zero mbar	make-up water requirements in m ³ /h		
				KB difference in temperature °C		FB
				5	2	
GPV 5112 + LPH 55320	1450	11	abt. 2	0.95	1.55	2.7

Suction pressure range 8 to 40 mbar

Service liquid temperature up to 15°C

gas ejector + liquid ring vacuum pump	pump speed rpm	rated power of the motor of the liquid ring vacuum pump kW	pressure at a suction volume flow = zero mbar	make-up water requirements in m ³ /h		
				KB difference in temperature °C		FB
				5	2	
GOV 3211 + LOH 25007	2800	1.5	5 ... 7	0.13	0.2	0.34
GOV 3212 + LOH 25309	2900	2.2		0.2	0.34	0.75
GPV 4011 + LPH 45008	1450	3		0.25	0.45	0.9
GPV 4012 + LPH 45316		5.5	4 ... 5	0.35	0.6	0.95
GPV 5011 + LPH 55312		7.5	5 ... 7	0.75	1.4	2.7
GPV 5012 + LPH 55320		11		0.95	1.55	
GPV 6011 + LPH 65320		15	4 ... 5	1.1	1.7	2.6
GPV 6012 + LPH 65327	18.5	1.2		1.8		

Suction pressure range 20 to 80 mbar

Service liquid temperature up to 30°C

gas ejector + liquid ring vacuum pump	pump speed rpm	rated power of the motor of the liquid ring vacuum pump kW	pressure at a suction volume flow = zero mbar	make-up water requirements in m ³ /h		
				KB difference in temperature °C		FB
				10	5	
GOV 3211 + LOH 25007	2800	1.5	17	0.08	0.13	0.34
GOV 3212 + LOH 25309	2900	2.2		0.11	0.19	0.75
GPV 4311 + LPH 45008	1450	3	13	0.15	0.25	0.85
GPV 4312 + LPH 45311		4		0.2	0.3	
GPV 4313 + LPH 45316		5.5		0.25	0.4	
GPV 5311 + LPH 55312		7.5	9	0.45	0.75	2.7
GPV 5312 + LPH 55316		11	12	0.5	0.85	
GPV 5313 + LPH 55320		11	9	0.6	0.95	
GPV 6311 + LPH 65320		15	8	0.7	1.1	2.6
GPV 6312 + LPH 65327		18.5		0.8	1.2	

FB = make-up liquid service

KB = combined liquid service, service liquid 10°C, 5°C or 2°C warmer than the make-up water

The make-up water flows refer to the lowest suction pressure indicated. In case of increasing suction pressure these figures decrease.

The values indicated suction volume flow are valid for compression of dry air of 20°C from suction pressure to atmospheric pressure (1013 mbar). Service liquid for the liquid ring vacuum pump also indicated is water to a temperature of 15°C resp. 30°C. The motive air for the gas ejector has a pressure of abt. 1013 mbar.

Motive and handling gases with physical characteristics which deviate from those of air, service water with other temperatures than those indicated, as well as other service liquids than water cause a change in suction capacity, which can be determined by Sterling SIHI on request.

Performance graph of the combinations

Suction pressure range: 4 to 12 mbar

for service liquid temperatures up to 15°C

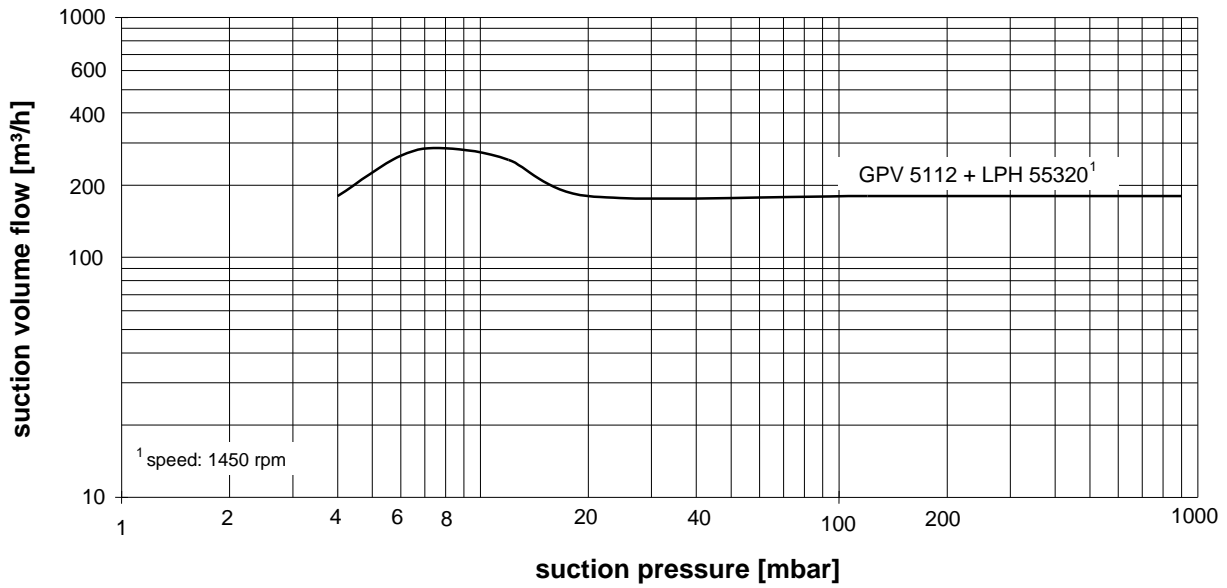

Suction pressure range: 8 to 40 mbar

for service liquid temperatures up to 15°C

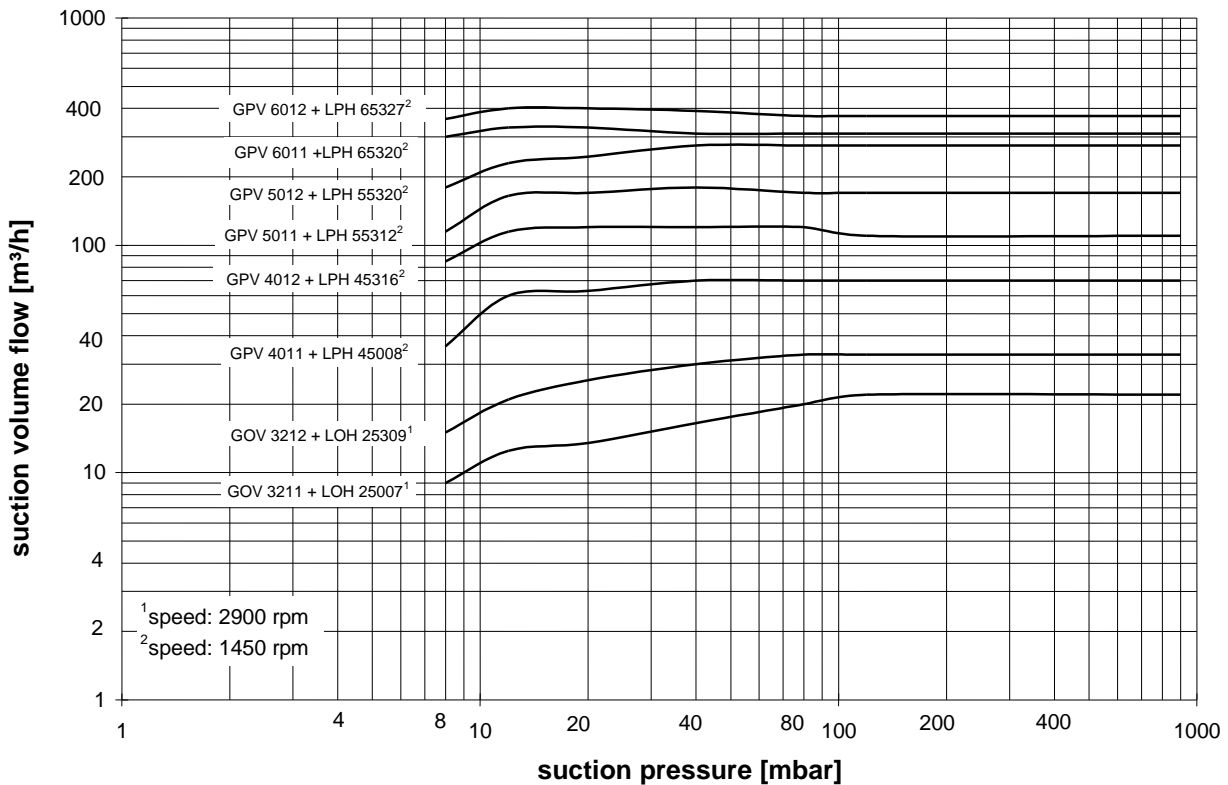

For the suction volume flow the tolerance is 10 %.

Performance graph of the combinations

Suction pressure range: 20 to 80 mbar

for service liquid temperatures up to 30°C

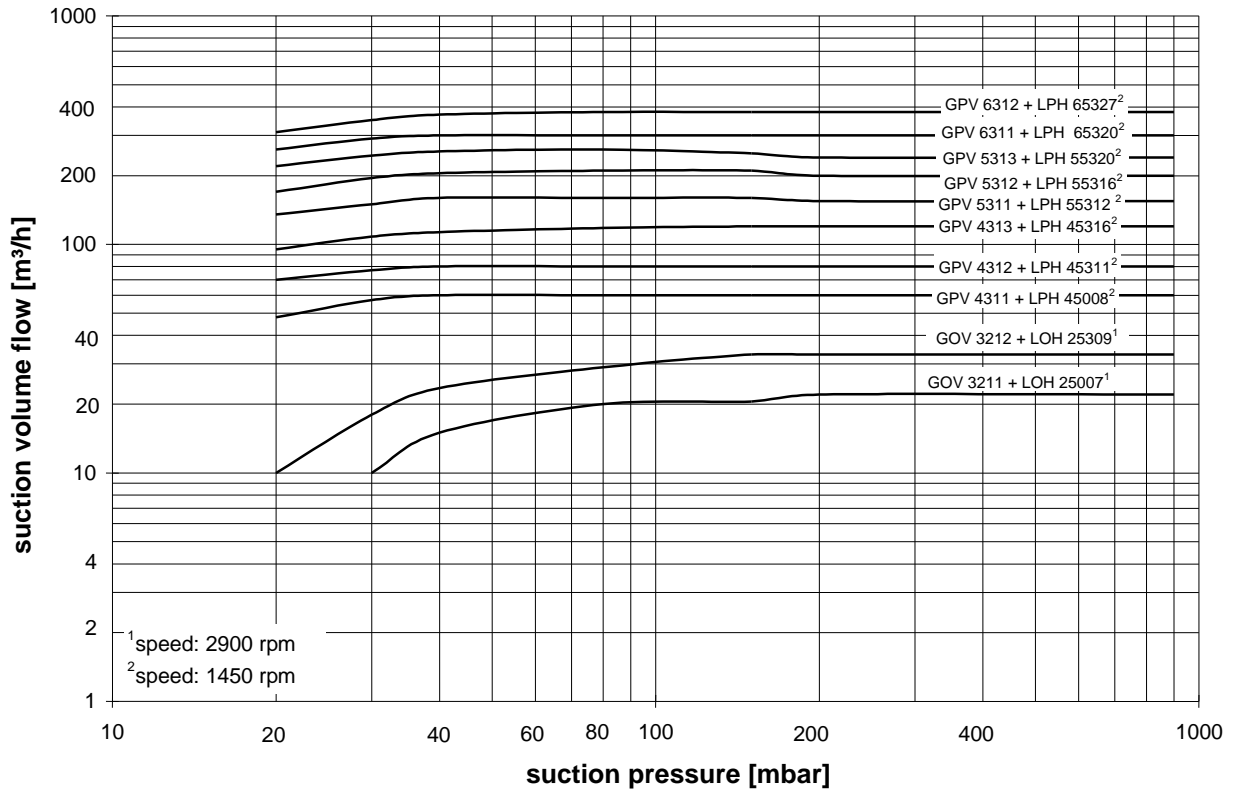

For the suction volume flow the tolerance is 10 %.

Dimension table

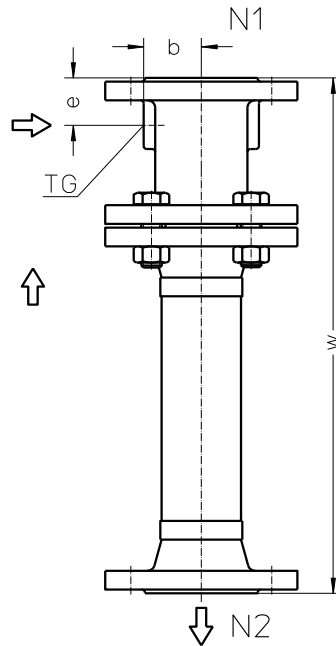

N1 = gas-inlet, N2 = gas-outlet, TG = motive gas inlet

series + size	N1 / N2	TG	b	e	w	weight in kg for material design	
						81	88
GOV 3211 GOV 3212	DN 32 *	G 1/4	36	22	230	3.5	4
GPV 4011 GPV 4012 GPV 4311 GPV 4312 GPV 4313	DN 40	G 1/2	45	38	413	11.5	13
		G 3/4	50	55	555	16	20
		G 1/2	45	38	315	11	12
					413	11.5	13
GPV 5011 GPV 5012 GPV 5112 GPV 5311 GPV 5312 GPV 5313	DN 50	G 1	55	55	653	20	25
		DN 32 *	54	70	714	23	30
		G 1	55	55	653	20	25
GPV 6011 GPV 6012 GPV 6311 GPV 6312	DN 65	DN 25 *	70	85	790	35	47
							48

* Flange suitable for counter-flange according to DIN 2558

Flange connections according to DIN 2501 PN 10				DIN 2558 PN 6	
DN	40	50	65	25	32
k	110	125	145	75	90
D	150	165	185	-	-
d ₂ x number	18 x 4	18 x 4	18 x 4	11 x 2	14 x 2
d ₄	88	102	122	-	-
s	16	18	18	-	-

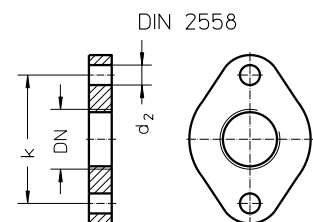
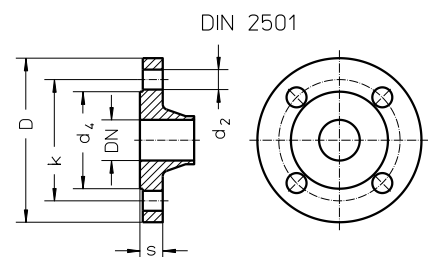

Example for ordering:

G P V • 4312 81 0
 series size material design casing sealing

On delivery the point (•) in the fourth place of the type code is replaced by a letter in the factory.

Any changes in the interest of the technical development are reserved.

Sterling SIHI GmbH

Lindenstraße 170, D-25524 Itzehoe, Germany, Telephone +49 (0) 48 21 7 71 - 01, Fax +49 (0) 48 21 7 71 274